

MICROWAVE MOTION SENSOR USER GUIDE

Model Number: OS/5.8



Technical Specifications :

Input Voltage	220-240Vac 50Hz
Rated Load	400W (inductive load), 800W (resistive load)
Detection Area	4-6m radius at 2.5m ceiling height (typical)
On time	5sec, 30sec, 180sec, 300sec, 15min, 25min
Daylight Sensor	2lux, 5lux, 20lux, 30lux, Disable
Sensor Principle	Microwave motion detector
Microwave Frequency	5.8GHz Continuous Wave
Transmitting Power	<0.5mW (1% of transmitting power of cell phone)
Parasitic Load	<1.7W (daylight/motion sensing only)
Operating Temperature	0°-50°C
IP Rating	IP20

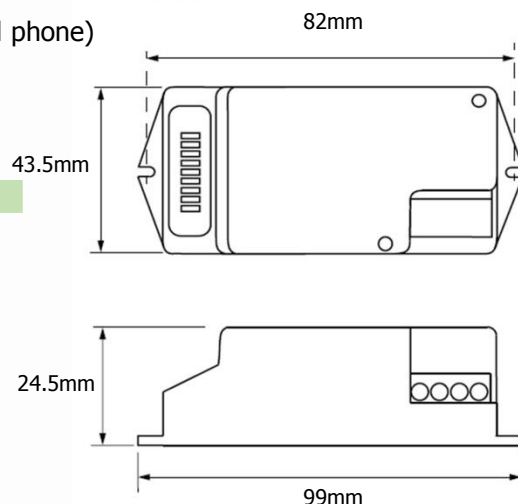

Compliance and Certification :



General Guidelines for Installation :

- Specifications for detection range and daylight sensor levels are typical. Suitability should be determined for sensitive applications.
- The motion sensor should be installed by a qualified electrician. Ensure that electricity supply is switched off before installing or servicing the product.
- The sensor should not be modified in any way. Any modifications to this product will immediately invalidate any warranties issued.
- The company does not accept responsibility for any consequences resulting from unauthorised modification of the product.
- The sensor should be connected to a stable power supply of 220-240Vac 50Hz.
- Microwaves cannot pass through metal or brick walls thicker than 20cm. They will pass through thinner walls but there will be some attenuation.
- Installation inside a glass or plastic housing will result in a reduction of sensitivity. Expect a reduction of approximately 20% for every 3mm of thickness.

Installation and Wiring :

The sensor is designed for installation 1-6m in height with a suggested mounting height of 1-1.8m (wall mounting) and 2.5-6m (ceiling mounting). For connecting one or several mains gears to one sensor, refer to the wiring diagram below:

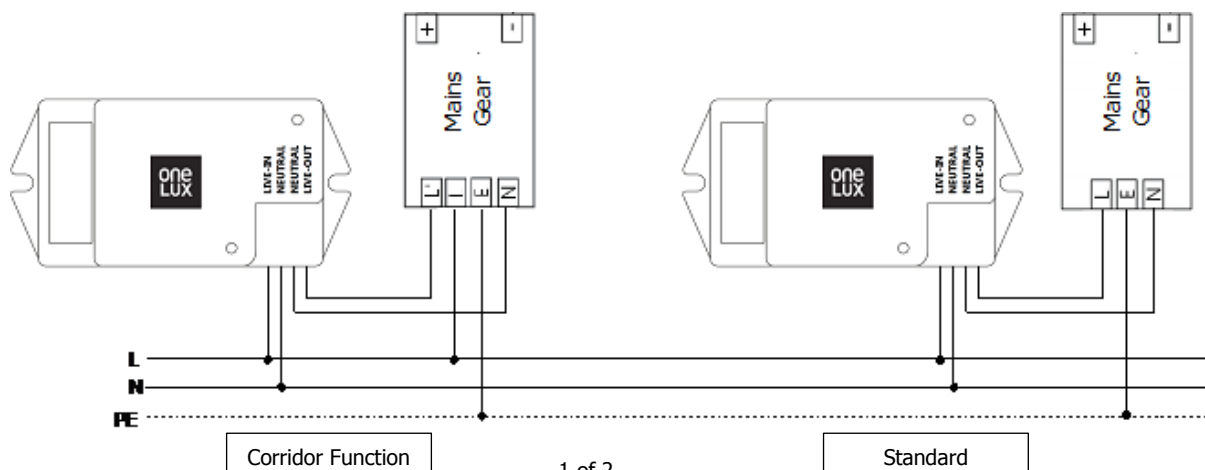

Settings :

Sensitivity, on time, and daylight settings can be configured via the DIP switches on the sensor. Note that units are supplied with all switches set to off. Reducing the sensitivity will reduce the detection area. Optimum performance may be obtained after an initial warm-up period.

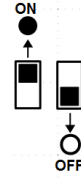

SENSITIVITY				ON TIME				LIGHT SENSOR			
1	2	3	SETTING	4	5	6	SETTING	7	8	9	SETTING
●	●	●	100%	●	●	●	5s	●	●	●	2 lux
○	●	●	75%	○	●	●	30s	○	●	●	5 lux
●	○	●	50%	●	○	●	180s	●	○	●	20 lux
●	●	○	25%	○	○	●	300s	○	●	○	30 lux
○	○	○	10%	●	●	○	15min	○	○	○	Disable
○	○	○		○	○	○	25min	○	○	○	

1) SENSITIVITY: Refers to the typical detection range sensitivity. Based on a person who is between 1.6m/1.7m tall moving at a speed of 0.1-1m/sec. (Detection range varies depending on the height and stature of a person).

- I : 100% - up to 6m radius
- II : 75% - up to 5m radius
- III : 50% - up to 4m radius
- IV : 25% - up to 3m radius
- V : 10% - up to 2m radius

2) ON TIME: Refers to the time period the lamp remains on after no motion is detected. Note that after the light switches off, it takes 2 seconds before the sensor starts detecting motion again. The Live-Out terminal is active 1.2 seconds after the sensor is powered up. When energised for the first time, there is a stabilisation period of approximately 10 seconds before normal operation starts. If adjusted while the sensor is on, the new on time will be implemented after the sensor turns off; to bypass this, simply cycle the supply mains.

- I : 5 seconds
- II : 30 seconds
- III : 180 seconds
- IV : 300 seconds
- V : 15 minutes
- VI : 25 minutes

3) LIGHT SENSOR: This can be configured to only allow the lamp to illuminate below a defined ambient brightness threshold. Settings are typical and as follows:

- I : 2 lux
- II : 5 lux
- III : 20 lux
- IV : 30 lux
- V : Disable - When set, the light sensor will switch on the lamp regardless of ambient light levels

FAQ :

Question	Cause	Remedy
The load does not turn on.	Incorrect light sensor setting.	Adjust light sensor setting.
	Load has failed.	Check or replace load.
	Power is switched off.	Check mains power is present.
The load does not turn off.	Continuous movement in the detection area.	Check sensitivity setting.
	The light fixture (containing sensor) is installed in an area too close to reflective surfaces; i.e. metal, glass or concrete walls.	(1) Make sure installation area is suitable with at least 30cm space between lamp and surrounding reflective surfaces; (2) Reduce sensitivity (detection area).
	The light fixture (containing sensor) is fixed to a vibrating surface (e.g., suspended luminaire).	Check installation surface is stable and free from any vibrations.
The load does not turn on despite movement.	Speed of moving object is not in the specified range.	Check detection area setting.
	Detection radius is too small.	