

**Product description**

Omni-LED DST™ is a range of DALI Self-Test emergency lighting conversion modules housed in a compact low-profile enclosure, and suitable for use with maintained, self-contained LED luminaires.

Their constant-power driver technology has a SELV isolated output and available in a range from 3V to 200VDC. They will run almost any LED lamp or array (including some GU10 and Linear tubes), so making it easy to produce a self-testing and addressable, emergency version of your existing LED luminaire without the need for separate 'emergency' LEDs or connectors.

They are available in 2, 3 and 4 cell versions for use with NiCd or NiMH batteries.

**Features**

- > Fully compliant DALI, self-contained emergency lighting device (type 1)
- > Intelligent, automatic self-test scheduling for non-DALI applications
- > Integral status/ identification sounder with user-override
- > Input for optional low-voltage emergency test initiation switch
- > Bi-colour red/ green status indicator LED with 500mm leads supplied as standard
- > User-selectable 1 or 3 hour autonomy
- > Emergency output power (Typical) : 1.5W (2-cell), 3W (3-cell), 4W (55V 4-cell ), 3.5W (90V 4-cell ) and 3W (200V 4-cell)
- > 3-pole switching provides full isolation of lamp connections and mains driver's power supply during emergency operation (Compatible with most driver types up to 2A)
- > Constant-current charger with reverse polarity and short-circuit protection
- > Designed and manufactured in Great Britain
- > Complies with: EN60598-2-22, EN61347-1, EN61347-2-7, EN61347-2-13, EN62034, EN62386, EN55015, EN61000-3-2, EN61547

Common Technical Data	
Input Supply Voltage	230V +/- 10%
Supply Frequency	50/60 Hz
Output Voltage of the Range	3 - 200 Vdc
Maximum TC Point	70°C
Ambient Temperature Range	0°C - 50°C
Battery Charge Time	24 Hours
Earth Leakage Current	<0.5mA
IP Rating	IP20
Weight	90g

Model Number	LED Voltage Range	Number of Battery Cells
OL12/2/M3/DST	3 - 12V	2
OL55/3/M3/DST	9 - 55V	3
OL55/4/M3/DST	9 - 55V	4
OL90/4/M3/DST	55 - 90V	4
OL200/4/M3/DST	90 - 200V	4

OL12 and OL55 products are SELV compliant.

All versions supplied in standard pack quantities of 50 weighing 5.0Kg

**Accessories**

See pages 5 to 7 for our range of batteries and battery accessories.

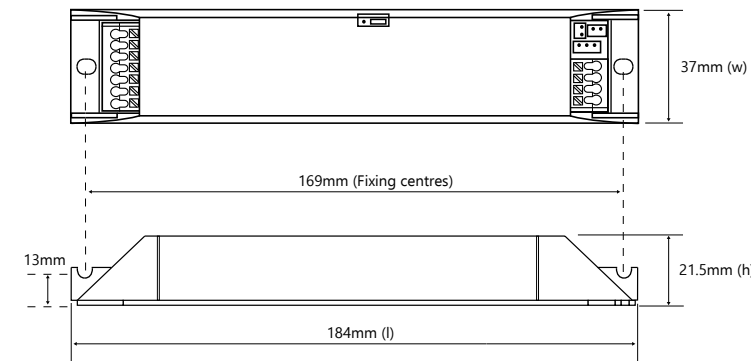

Product specifications may be subject to change without prior notice.

Issue\_8 August 2023



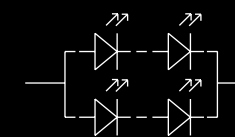

TECHNICAL INFORMATION

Model Number	Input Characteristics - Charging Mode				
	Duration selection	Circuit Watts*	Input Current	Inrush Current	Power Factor
OL12/2/M3/DST	1 Hour	2.8W	0.03A	5A pk	0.45
	3 Hour	3W	0.03A	5A pk	0.45
OL55/3/M3/DST	1 Hour	2.8W	0.03A	5A pk	0.44
	3 Hour	4.2W	0.04A	5A pk	0.47
OL55/4/M3/DST, OL90/4/M3/DST, OL200/4/M3/DST	1 Hour	3.4W	0.04A	5A pk	0.45
	3 Hour	4.8W	0.05A	5A pk	0.45

\* This figure may be used for LENI 'Parasitic Power' calculations.

Model Number	Battery & Emergency Output Characteristics											
	Autonomy Setting	Battery Type	Number of Battery Cells	Battery Capacity	Battery Volts Range (Charge Mode)	Battery Charge Current	Battery Volts Range (Discharge Mode)	Battery Discharge Current Nominal/ Range	DDP Voltage	LED Voltage Range	MaxOutput Power **	Uout Max (open Circuit)
OL12/2/M3/DST	1 hour	NiCd/ NiMH	2	1.6Ah	1.5 - 4V	75-95mA	2 - 2.8V	1.05A /(0.8 - 1.2A)	1.8V (min)	3 - 12V	2W	50V
	3 hours		2	4Ah	1.5 - 4V	140-260mA	2 - 2.8V	1.05A /(0.8 - 1.2A)	1.8V (min)	3 - 12V	2W	50V
OL55/3/M3/DST	1 hour		3	1.6Ah	1.5 - 6V	75-95mA	3 - 4.2V	1.05A /(0.8 - 1.2A)	2.5V (min)	9 - 55V	3.4W	80V
	3 hours		3	4Ah	1.5 - 6V	140-260mA	3 - 4.2V	1.05A /(0.8 - 1.2A)	2.5V (min)	9 - 55V	3.4W	80V
OL55/4/M3/DST	1 hour		4	1.6Ah	1.5 - 8V	75-95mA	4 - 5.6V	1.05A /(0.8 - 1.2A)	3.5V (min)	9 - 55V	4.5W	80V
	3 hours		4	4Ah	1.5 - 8V	140-260mA	4 - 5.6V	1.05A /(0.8 - 1.2A)	3.5V (min)	9 - 55V	4.5W	80V
OL90/4/M3/DST	1 hour		4	1.6Ah	1.5 - 8V	75-95mA	4 - 5.6V	1.05A /(0.8 - 1.2A)	3.5V (min)	55 - 90V	4W	100V
	3 hours		4	4Ah	1.5 - 8V	140-260mA	4 - 5.6V	1.05A /(0.8 - 1.2A)	3.5V (min)	55 - 90V	4W	100V
OL200/4/M3/DST	1 hour		4	1.6Ah	1.5 - 8V	75-95mA	4 - 5.6V	1.05A /(0.8 - 1.2A)	3.5V (min)	90 - 200V	4W	220V
	3 hours		4	4Ah	1.5 - 8V	140-260mA	4 - 5.6V	1.05A /(0.8 - 1.2A)	3.5V (min)	90 - 200V	4W	220V

\*\* See graphs on pages 3 and 4 for output characteristics.

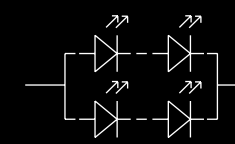

TECHNICAL INFORMATION

LED lamp output - Shaded area indicates typical forward voltage (Vf) vs forward current (If) expected throughout discharge duration.

1.5W - OL12/2/DST

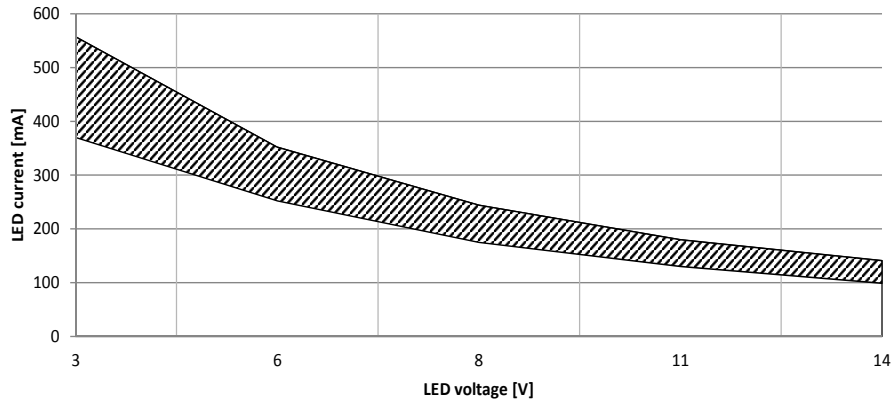

3W - OL55/3/DST

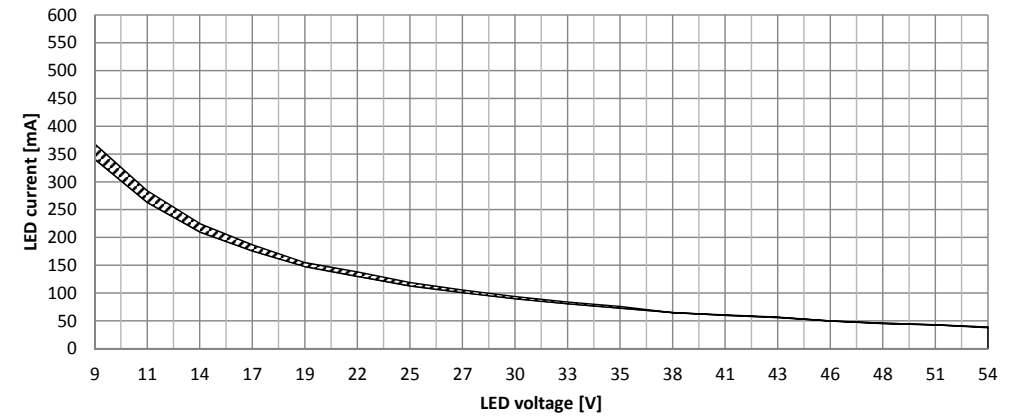

4W - OL55/4/DST

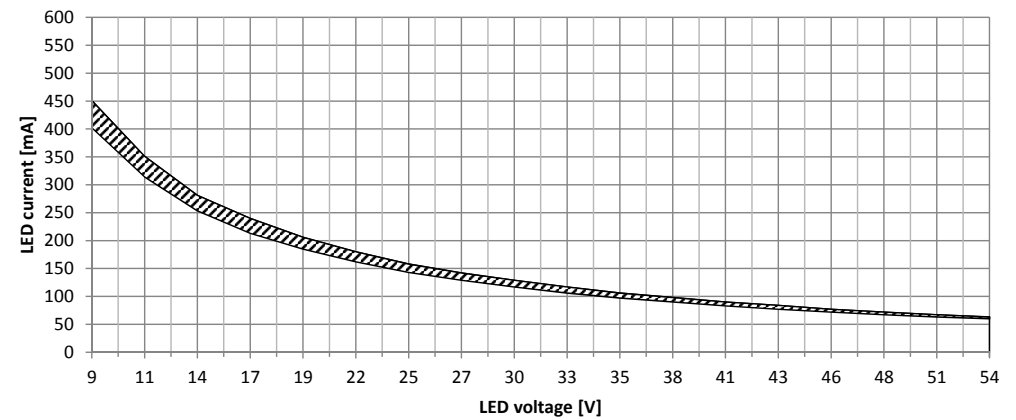

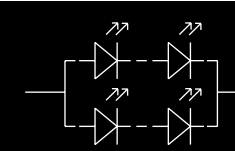

TECHNICAL INFORMATION

LED lamp output - Shaded area indicates typical forward voltage (Vf) vs forward current (If) expected throughout discharge duration.

3.5W - OL90/4/DST

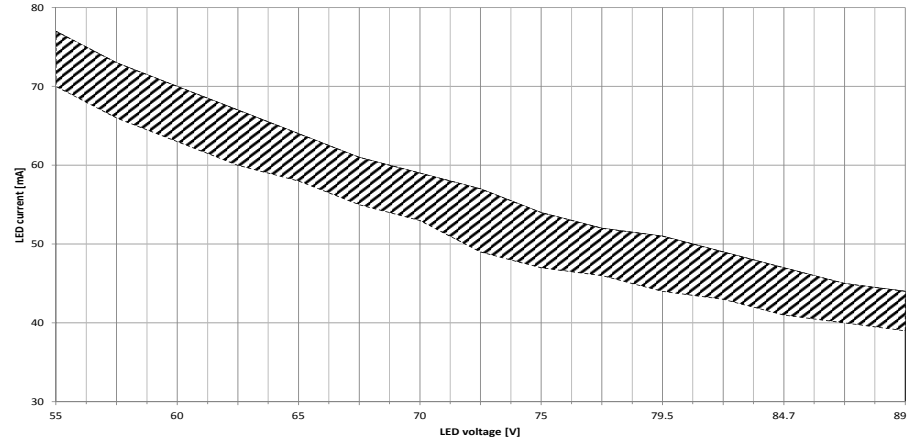

3.0W - OL200/4/DST

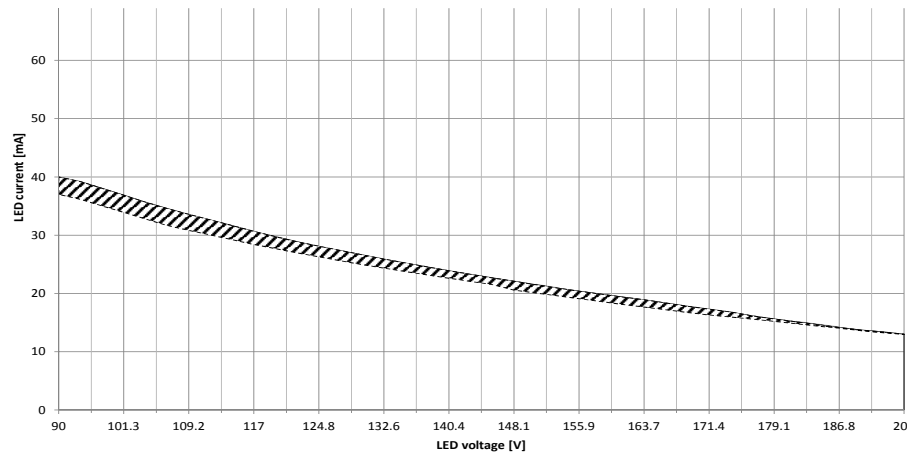

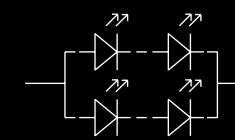

BATTERY AND END CAP ACCESSORY ASSIGNMENT

Applicable Battery Packs and End Caps to OMNI-LED™ models

Model Number	Duration selection	NiCd Batteries									NiMH Batteries		
		NCD24SS	NCD24BS	NCD34SS	NCD34BS	NCD44SS	NCD44BS	NCD216SS	NCD316SS	NCD416SS	NMH24SS	NMH34SS	NMH44SS
Applicable End Caps (2 required per battery)		E	-	E	-	E	-	E/Sub C	E/Sub C	E/Sub C	E/18700	E/18700	E/18700
OL12/2/M3/DST	1 Hour							4					
	3 Hour	4	4								4		
OL55/3/M3/DST	1 Hour								4				
	3 Hour			4	4							4	
OL55/4/M3/DST, OL90/4/ M3/DST, OL200/4/M3/DST	1 Hour									4			
	3 Hour					4	4						4

BATTERY END CAPS

Product description

- > End caps suitable for use with 'stick' D size batteries
- > End cap suitable for use with 'stick' Sub C batteries
- > End cap suitable for use with 'stick' 18700 Nickel Metal Hydride batteries

Properties

- > Provides a convenient and secure mounting option for cylindrical batteries
- > Moulded in UL94-V0 rated plastic
- > 'E' version offers slide together feature to produce secure side-by-side configuration
- > Link wires available separately
- > Slotted for tag connection or outlet for pre-soldered connections

NiCd Batteries - Ordering Information				
Product Code	E	E/Slotted	E/18700	E/Sub C
Fixing Centers when fitted	Battery Length (L) + 20mm	Battery Length (L) + 17mm	Battery Length (L) + 16mm	Battery Length (L) + 19mm
Maximum Length when fitted	Battery Length (L) + 37mm	Battery Length (L) + 34mm	Battery Length (L) + 23mm	Battery Length (L) + 40mm



ACCESSORIES | NICKEL CADMIUM (NiCd) BATTERIES

**Product description**

- > High temperature Nickel Cadmium batteries for Emergency Lighting use
- > Suitable for use with all One-LUX products
- > 1-year warranty

**Properties**

- > Rated for continuous operation at 55°C and meets the 4 year design life as per Annex A of EN60598-2-22
- > Complies with IEC61951-1
- > Supplied with suitable connectors
- > Available in custom configurations
- > 4Ah 'D' size cells
- > Other capacities available
- > Refer to battery data sheet for further information

Common Technical Data	
Absolute Maximum Temperature	70°C
Maximum Continuous Temperature	55°C
Minimum Ambient Temperature	5°C
Charge Requirements	C/20 for 24 hours Constant Current (CC)
Storage	0-25°C for 12 months
Disposal at registered treatment facility only	

Table of Dimensions									
Dimensions	NCD24SS	NCD24BS	NCD34SS	NCD34BS	NCD44SS	NCD44BS	NCD216SS	NCD316SS	NCD416SS
Length (L)	116mm	68mm	175mm	102mm	234mm	136mm	86mm	131mm	175mm
Width (W)	34mm	63mm	34mm	63mm	34mm	63mm	23mm	23mm	23mm
Height (H)	34mm	36mm	34mm	36mm	34mm	36mm	23mm	23mm	23mm
Fixing (l)		n/a		32mm		64mm			
Fixing (w)		40mm		40mm		40mm			
IEC Cell Size	'D'					'Sub-C' (SC/Cs)			

NiCd Batteries - Ordering Information								
Product Code	NCD24SS	NCD34SS	NCD34BS	NCD44SS	NCD44BS	NCD216SS	NCD316SS	NCD416SS
Box Quantity	40	30	30	20	22	140	60	60
Weight	11kg	12kg	13kg	10.8kg	12kg	14.5kg	10kg	12kg

NiCd Cable Assemblies	Connector Type	Wire Length	Connector Dimensions
CAS031 required with packs (BS) (Sold separately)	Mini JST plug to Amp 'mate-n-lok' (male)	250mm	N/A N/A
CAS020 required with sticks (SS) (Sold separately)	Mini JST plug to Red & Black wires with sockets	500mm	4.8mm x 0.8mm 6.3mm x 0.8mm
CAS012 - link wire (Sold separately)	White wire (female/female)	100mm	6.3mm x 0.8mm (positive) 4.8mm x 0.8mm (negative)

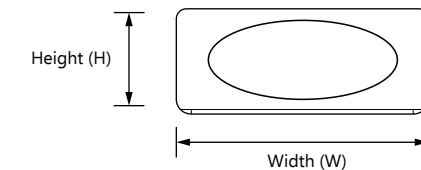
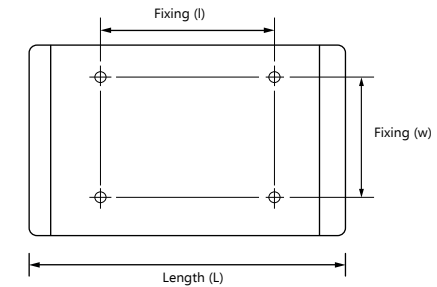
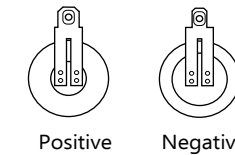
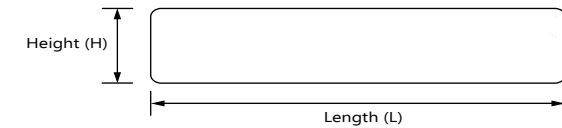

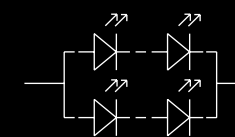

ACCESSORIES | NICKEL METAL HYDRIDE (NiMH) BATTERIES

**Product description**

- > High temperature Nickel Metal Hydride batteries for emergency lighting use
- > Suitable for use with all One-LUX products
- > 1-year warranty

**Properties**

- > Rated for continuous operation at 50°C and meets the 4 year design life as per Annex A of EN60598-2-22
- > Complies with IEC61951-2
- > Supplied with suitable connectors
- > Available in custom configurations
- > 4Ah '18700' size cells
- > Other capacities available
- > Refer to battery data sheet for further information

Common Technical Data	
Absolute Maximum Temperature	70°C
Maximum Continuous Temperature	50°C
Minimum Ambient Temperature	5°C
Charge Requirements	C/20 for 24 hours Constant Current (CC)
Storage	0-25°C for 6 months
Disposal at registered treatment facility only	

Table of Dimensions			
Dimensions	NMH24SS	NMH34SS	NMH44SS
Length (L)	140.5mm	214.5mm	284mm
Diameter (D)	20mm	20mm	20mm
IEC Cell Size	'18700'		

NiMH Batteries - Ordering Information			
Product Code	NMH24SS	NMH34SS	NMH44SS
Box Quantity	50	45	54
Weight	7kg	11kg	14.5kg

NiMH Cable Assemblies	Connector Type	Wire Length	Connector Dimensions
CAS024/JST - wire set (Sold separately)	Mini JST plug to Red & Black wires with spade & socket	700mm	Red 4mm (socket) Black 3.5mm (spade)
CAS070 - link wire (Sold separately)	Black wire (male/female)	300mm	3.5mm & 4mm (spade & socket)



Nickel Metal Hydride (Ni-MH)

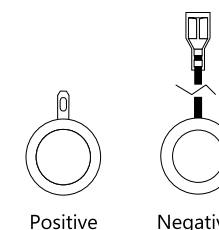
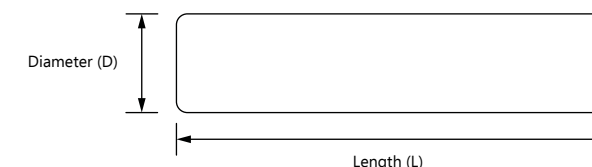

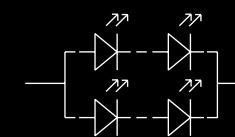

## INSTALLATION

### Disclaimers

Omni-LED DST™ module and its associated accessory products have been manufactured and designed to comply with the requirements of EN60598-2-22 in addition to the standards detailed on page 1 of this document. Operation beyond the parameters specified in this document and the associated standards may result in reduced performance and ultimate premature failure, with the warranty made void. It is the users responsibility to ensure full compatibility of the Omni-LED DST product for the intended application and for compliance of the emergency conversion to relevant Standards. The specifier/ system designer should follow the luminaire manufacturer's specifications and be aware of the environment to which the luminaire and these components are used and ensure compatibility of One-LUX products with other components in the lighting/ DALI system. Installation should be in line with the following guides. Please contact our Technical department if you are in any doubt.

### Precautions

Omni-LED DST™ module should be installed as per the following guidelines, electric shock or damage to the product may result if incorrectly installed. The luminaire should be installed by a qualified and competent electrician. If the luminaire is to be mounted in an external location, consider the battery as temperatures below 0°C may be frequent in cold months. In this case, the design life of 4 years will be compromised and more frequent battery replacements may be needed. Likewise, if the luminaire is situated in a hot environment where the temperature is maintained at 25°C or above, or sited next to large panes of glass in which case it may be exposed to thermal magnification.

It is recommended that IP65 luminaires are avoided for use in internal applications as undue thermal stress may result.

### Installation notes

Wire Preparation: maximum strip length 10mm (recommended 6mm)  
Min/max Conductor sizes: 0.5 - 1.5 mm<sup>2</sup>.

Best effort should be made to keep the Omni-LED DST™ module and battery away from direct sources of heat, i.e. mains LED drivers and LED lamps. Avoid obstructing airflow around the sides of the Omni-LED DST™ module and other electronic products. Allow a clearance of 10mm or more wherever possible.

Lamp Connections should be kept as short as possible and under no circumstances exceed 1m for self-contained luminaires. The Omni-LED DST™ module should be secured using both fixing points and the use of M4x 6mm screws are recommended for most applications.

### Test Switch input (Optional accessory)

The Omni-LED DST™ module offers the facility for the user to perform a multiple functions with a switch connected to the 'TEST SWITCH' input. A non-latching push-to-make switch should be used as shown in the wiring diagrams on Page 11. See below for details of use.

Test Switch Information	
Function	Test Switch Action
Disable Sounder	Press and hold for longer than 5 seconds (Sounder beeps once for confirmation)
Enable Sounder	Press and hold for longer than 5 seconds (Sounder beeps twice for confirmation)
Start a Function Test*	Press and release 2 times within 5 seconds
Confirm physical selection	Press once during physical selection mode initiated by DALI system
Stop Identification	Press once during identification mode to exit.

EMC considerations: Mains input connections should be as far from the lamp leads as possible and no ideally less than 10cm. Mains input wires should be as short as possible and run direct from input terminations to the Omni-LED DST™ product; they should not run alongside the case.

Other EMC tips:

- > Keep the lamp wires raised off any earthed metalwork
  - > Twist mains leads together when 'looping' or 'through wiring'
- The switched and un-switched lives may be joined together for continuous operation (un-switched) applications. The Omni-LED DST™ module provides SELV reinforced insulation between the mains supply and battery charging circuit and employs self-resetting

protection against short-circuit of battery terminals. Normal charging will resume automatically once a fault is removed. The mains supply should always be disconnected when servicing the luminaire.

If other devices are connected to the un-switched supply, please be aware that to maintain compliance with EN60598-2-22 that in event of its failure it will not affect other devices on the same circuit. In this case we recommend the use of separate fused terminal blocks to each device.

Internal fuses used within Omni-LED DST™ module product are not user serviceable.

**CAUTION! Ensure the jumper setting located in the product lid is configured correctly for the intended application and the associated battery is of the correct capacity. See battery selection guide on page 5.**

Autonomy Selection Information	
Emergency Duration Required	Jumper Setting
3 Hours (Default Setting)	 <b>Omni-LED</b>
1 Hour	 <b>Omni-LED</b>



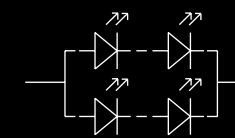

## INSTALLATION & OPERATION

### Commissioning:

Once the luminaire has been installed and availability of the un-switched supply is deemed stable, **connect the battery, then apply mains power.** After applying power, the Omni-LED DST™ will determine if there is a DALI bus present and or not. With **no** bus present, the indicator LED will flash red then green and the module will automatically carry out an initial 24 hour charge and a then a full Duration Test. Once this commissioning test is complete, a further 24 hours will be needed to recharge the battery before normal use. If a DALI bus **is** present, the module will begin standby/ charge mode and await further instruction from the DALI master.

The duration of stand-alone self tests, and capability of the product recognised by a DALI master will be determined by the configuration link, which is accessible through the enclosure lid. (See page 8 for details).

**Caution should be taken to ensure the battery charge current compatibility before adjusting configuration.**

If it is anticipated that the un-switched supply may be interrupted before normal use, we advise that the battery is left disconnected and commissioning is delayed until the supply is stable. If mains is not applied after connecting the battery, the unit will continue to draw a minimal amount of power from the battery whilst in standby mode. **Continued use in this state in excess of several months can cause permanent damage to some batteries.**

It may be necessary to repeat the initial charge/discharge process several times to re-condition the battery and achieve full rated emergency duration. This can be initiated by cycling the unswitched mains supply off and on, or activating the test switch twice within 5 seconds. After successful commissioning, the battery should be marked with the date of commission.

### Automatic Testing

If Standalone Self-Test mode is detected, the module will establish randomised delay times to ensure the next scheduled tests do not coincide with the same test of adjacent luminaires. (See table below for details of 'Test Delay Time' ranges).

Subsequent routine testing will then take place according to the 'Test Interval' times detailed in the table below.

When a scheduled test is due, the Omni-LED DST™ module will check status of the 'Control Switch Live Lin' to try and determine if the lamp is already in use and avoid disruption to the user for up to 36 hours wherever possible.

If the Omni-LED DST™ module has detected it is installed on a DALI network, it will configure itself according to the default DALI specification. (See table below). **It is important to note that in DALI mode, randomisation will not be set and it will await test delay times to be configured by the DALI master.**

In the event of loss of communication with the DALI master, automatic testing will revert back to the Self-Test 'Test Intervals', but 'Test Delay Times' will remain as configured by the DALI master.

An Omni-LED DST™ module can be returned to standalone self test at any time by disconnecting it from the DALI network and forcing a Function Test from the test switch or by cycling the un-switched mains supply. (See page 10 for details).

To fully reset all test times, disconnect the mains, battery power and DALI connections. Once power is restored, the commissioning cycle and randomisation process will be re-initiated.

Short discharge periods each month for the Function Test will not adversely affect One-LUX batteries and should be considered as a maintenance exercise for the battery. Regular full discharge cycles will however adversely affect the design life of the battery, so excessive testing should be avoided wherever possible.

A full summary of automatic test timings can be seen in the table below.

The status of the Omni-LED DST™ module can be determined at any time from the indicator LED. Details of the indicator LED status conditions and optional test switch functionality can be found on page 10.

### Automatic Testing Information

Test Type	Mode	Duration	Test Delay time	Test Interval / Occurrence	Notes
Commissioning Test	Self-Test	1 or 3 Hours*	24 Hours	Once*	The module will carry out a Duration Test 24 hours after initial power up. *This test cycle will be repeated if un-successfull Caution! An initial Duration Test must be initiated by the DALI Master to commission a new installation.
	DALI	1 or 3 Hours*	N/A	N/A	
Function Test	Self-Test	20 Seconds	1-15 Days	Every 28 Days	-
	DALI	20 Seconds	0	Every 7 Days	Caution! Factory default of zero test delay time is set for DALI Mode
Duration Test	Self-Test	1 or 3 Hours*	1-51 Weeks	Every 51 Weeks	The module checks if the lamp is in use before initiating a test to avoid disruption. Maximum test delay is 36 hours
	DALI	1 or 3 Hours*	0	Every 52 Weeks	Caution! Factory default of zero test delay time is set for DALI Mode

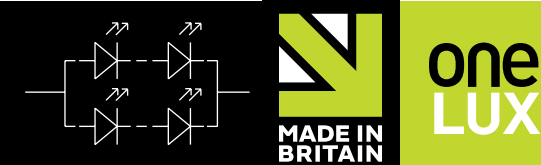

INSTALLATION & OPERATION Continued

Module Status Information								
LED Colour	LED Status	On Time (Seconds)		Off Time (Seconds)		Sounder	Purpose	Action required
Green	Steady On, or Very Slow Flash	Permanent 10		0 0.5		-	Normal status with fully charged battery (Commissioned unit)	None - In standby mode and operating as normal
	Slow Flash	1.5		0.5		-	First 24 hour charge and Duration Test. (Non-Commissioned unit)	None - Await commissioning process to complete
	Fast Flash	0.5		0.5		-	Function Test or Duration Test in progress. (Commissioned unit)	None - Await current test to complete
Varied		On	Off	On	Off		Purpose	Action required
Green	Long 'On' then flash	10	0.5	0.5	0.5	-	Battery being charged (Commissioned or DALI bus present unit)	None - Await battery to charge (Normally 24 Hours)
Red & Green (alternate)	Fast Flash	0.5	0.5	0.5	0.5	-	Physical select enabled by DALI system only	Confirm Physical select with optional Test Switch

Module Status Information (Fault Conditions) \*A function test can also be initiated at anytime whilst mains power is present by shorting the test switch off-on, 2 times within 5 seconds. A push switch is also available.

LED Colour	LED Status	On Time (Seconds)	Off Time (Seconds)	Sounder	Cause	Suggested action required
Red	Slow Flash	0.5	1.5	Yes	1) Possible initial commissioning duration test failed:  2) Possible battery connection fault:  3) Possible open circuit or short circuit battery:  4) Possible battery capacity fault:	1) If it is a new installation, you can determine if the Omni-LED DST™ passed the initial commissioning duration test by cycling the mains power off then on, whilst observing the indicator LED.  a) If the indicator LED flashes red then green at power on, the Omni-LED DST™ module did not pass its initial commissioning duration test and was awaiting further instruction. Cycling the power as per above has now reset the process and a new test will be attempted in 24hs time. (As long as the mains supply is not interrupted). This process may need to be repeated several times to re-condition new batteries to restore full capacity, especially if they have been in storage for some time.  b) If after cycling the mains power off then on, the red indicator remains, the unit has passed its commissioning test, but may have failed a routine function or duration test because of the causes below.  2) Whilst the mains supply remains on, check the battery connections and repair/ replace faulty parts if necessary. Initiate a function test to try and clear the fault indication. If the fault indication does not clear, proceed to 3).  3) Whilst the mains supply remains on, disconnect the battery and measure if its voltage is between 0.8 - 1.6V DC per cell. If its outside this range, the battery is faulty so it should be replaced. If a new one is installed, cycle the mains power off then on before reconnecting to initiate the commissioning process. If the voltage is within the range, proceed to next step.  4) To test the battery capacity, ensure it has had 24 hours uninterrupted charge, then turn off the mains power and observe if the rated emergency duration is achieved. If it exceeds the rated duration, you can reinstate power and initiate a function test to clear the fault indication. If the rated duration is not achieved, and it was a commissioned battery before, replace the battery and turn the mains power on to initiate a new commissioning test. (See page 9).
	Fast Flash	0.5	0.5	Yes	1) Possible lamp fault:  2) Possible internal circuit fault:	1) Check the lamp and wiring for faults or damage. Repair/replace as necessary. Initiate a function test to see if the fault has cleared. If the fault does not clear, proceed to step 2) <b>Caution, high voltages can be present at the lamp when the battery is connected even if the mains power is turned off!!</b>  2) If repairing/ replacing the lamp or wiring does not clear the fault, there may be a problem with the Omni-LED DST™. Turn off mains power, replace the module and reinstate power to commission the new module.

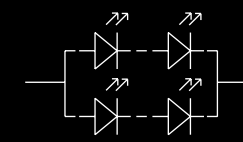

INSTALLATION

Non-Maintained

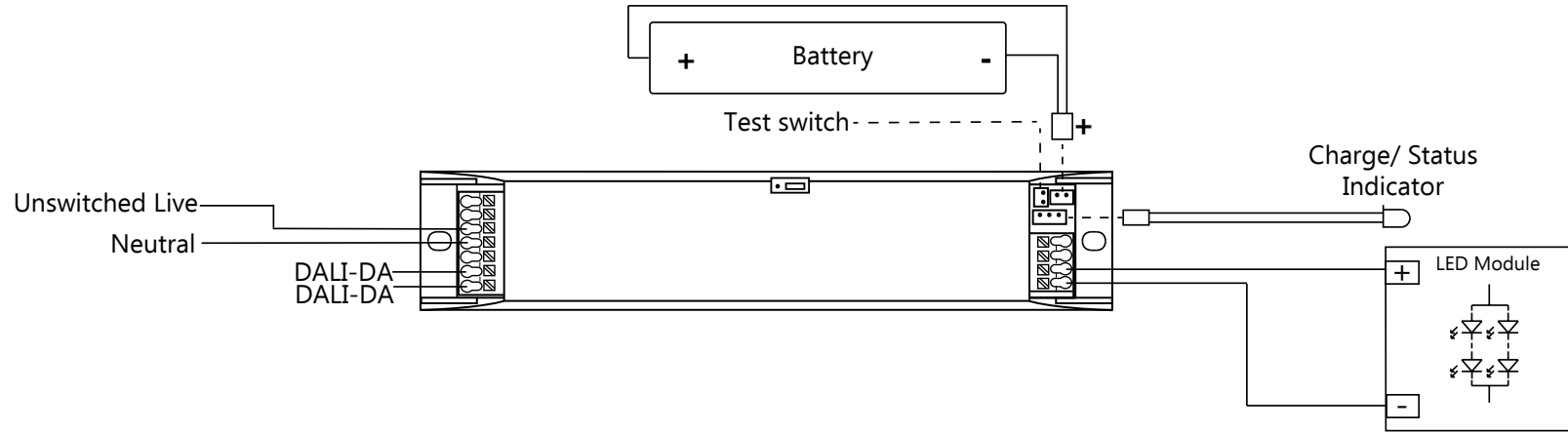

Maintained

