

## Universal Remote Emergency Pack

### Product Specification

- Mains voltage:	230VAC ± 10%
- Mains frequency:	50 - 60Hz
- Power Consumption (Excluding external Driver):	4VA
- Emergency output voltage range:	(See product label)
- Emergency Duration:	(See product label)
- Battery:	(See product label)
- Maximum LED current in maintained mode	2A
- Allowed ambient temp:	+5°C to +35°C
- Weight	0.4kg
- Charging time:	24 hours
- Protection class:	2
- Degree of protection:	IP20
- Em module complies with:	IEC 61347-2-7
- Suitable for installation to EN50172 and BS7671	

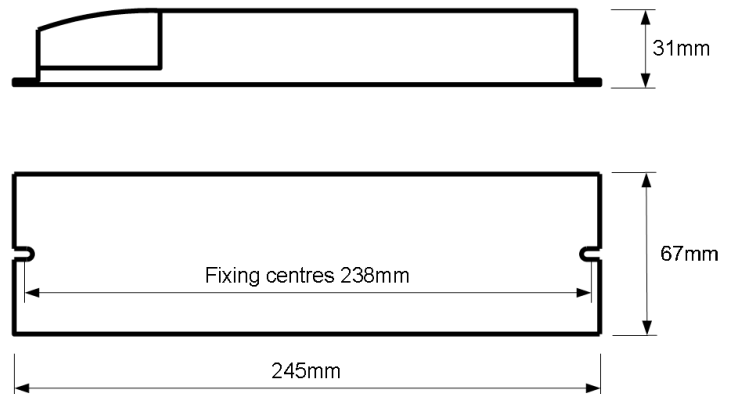

*The unit provides reinforced insulation between the mains supply and battery charging circuit and employs self-resetting protection against short-circuit of battery terminals. Normal charging will resume automatically once a fault is removed.*

### Installation

**NOTE** – To comply with regulations, installation must be carried out by a suitably qualified competent person and in accordance with the current IEE wiring regulations (BS7671) and building regulations.

#### Ensure the mains supply is isolated before attempting installation!

The emergency pack is for use with LED Modules only and can be supplied in several different wiring formats. Please refer to the appropriate diagram on page 2 of this leaflet for details of mains supply, LED driver, battery and lamp connections.

If non-locking external plug and socket connectors are used, i.e. without means to prevent accidental disconnection, the remote box should be sited so that it is protected from unauthorised disconnection.

A recessed plastic bezel can be found inside the packaging carton to assist installation of the indicator LED. A 14-16mm hole should be drilled in the required location so it is visible during normal use.

Before use, the battery will need to be connected by plugging in the red and black lead into the appropriate socket, (See diagrams on page 2).

To avoid subjecting the battery to excessive charge/ discharge cycles during installation stages, it is strongly recommended the battery is only connected when the mains supply is stable and the product is ready for commissioning.

Once all the necessary connections have been made, affix cable clamps to secure cables in place, place the plastic end cover on and fix with screws provided to prevent unauthorised access.

When the un-switched mains supply is turned on, the green indicator LED should be illuminated as follows:

- LED on: Mains supply OK, battery connected and charging.
- LED off: Mains supply is off [or below 160V], the battery is not connected or possible faulty unit.

### Commissioning

Once the luminaire has been installed and basic emergency functionality checked, the battery should be allowed to charge for a minimum period of 24 hours before testing for its rated duration. If it is anticipated that the un-switched supply may be interrupted, it is strongly recommended that the battery is left disconnected and commissioning is delayed until the supply is stable. If the luminaire has been stored for a number of months, it may be necessary to repeat the charge/discharge process several times to re-condition the battery. After successful commissioning, the battery box label should be marked with the date of the test and the Engineer responsible.

### Emergency Lighting 'standard' or 'manual' Test

The following minimum ongoing inspections and tests should be carried out:

#### Monthly

Switch off the mains power supply to the lighting unit. Inspect all emergency lights for satisfactory operation.

#### Yearly

Switch off the mains power supply to the lighting unit. Leave the unit to run for the rated period (e.g. three hours). The lights should remain operable from the battery for the whole period.

Any defects should be noted and rectified by a competent person as soon as possible. Please be aware that further inspection / testing may be required, e.g. by risk assessment / local legislation.

### Batteries and Disposal

The battery has a designed service life of 4 years and must be replaced in a timely manner to ensure the integrity of the emergency lighting system is maintained. In any case, the battery should be replaced when it no longer provides the rated duration (3 hours).

The manufacturer of the emergency pack is committed to fulfil its obligations as a producer of batteries used in emergency lighting applications. End-of-life batteries may either be returned to the emergency pack manufacturer at the customers cost and arrangements will be made to ensure their correct disposal. Alternatively it may be more convenient for the customer to deliver end-of-life batteries to site(s) of authorized treatment facilities at their cost and it will be ensured that they are accepted back and subsequently treated to the standard required by the regulations.

# Installation & Operating Instructions

## External wiring connections (Standard)

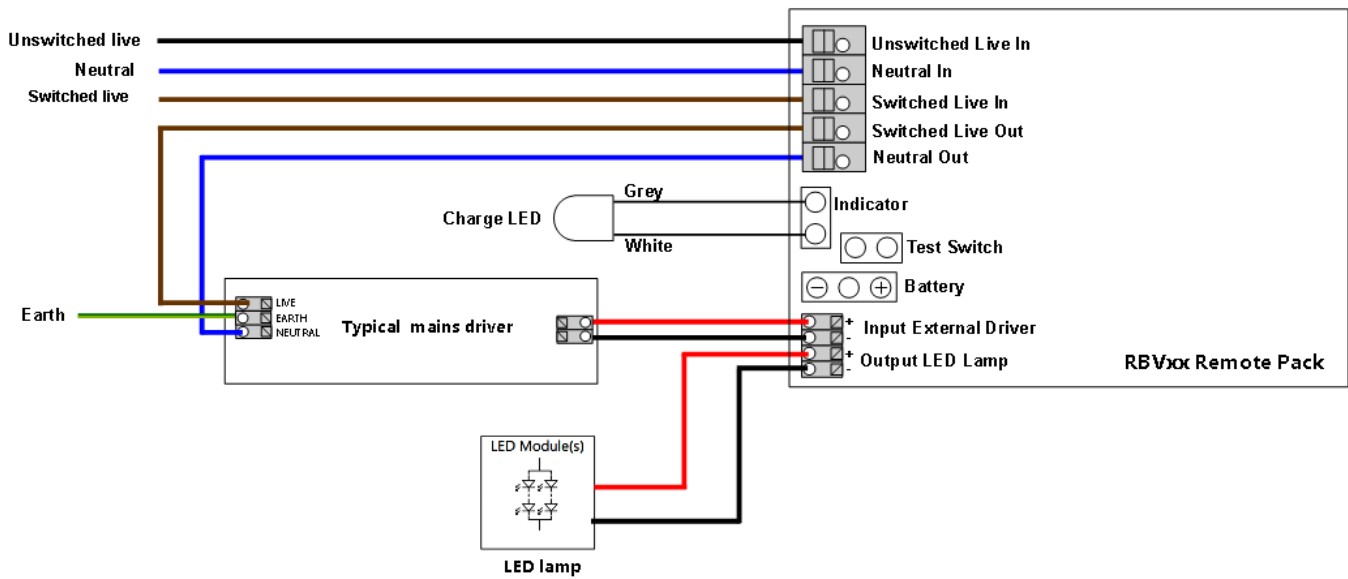

## External Wiring connections (With jack plug connectors)

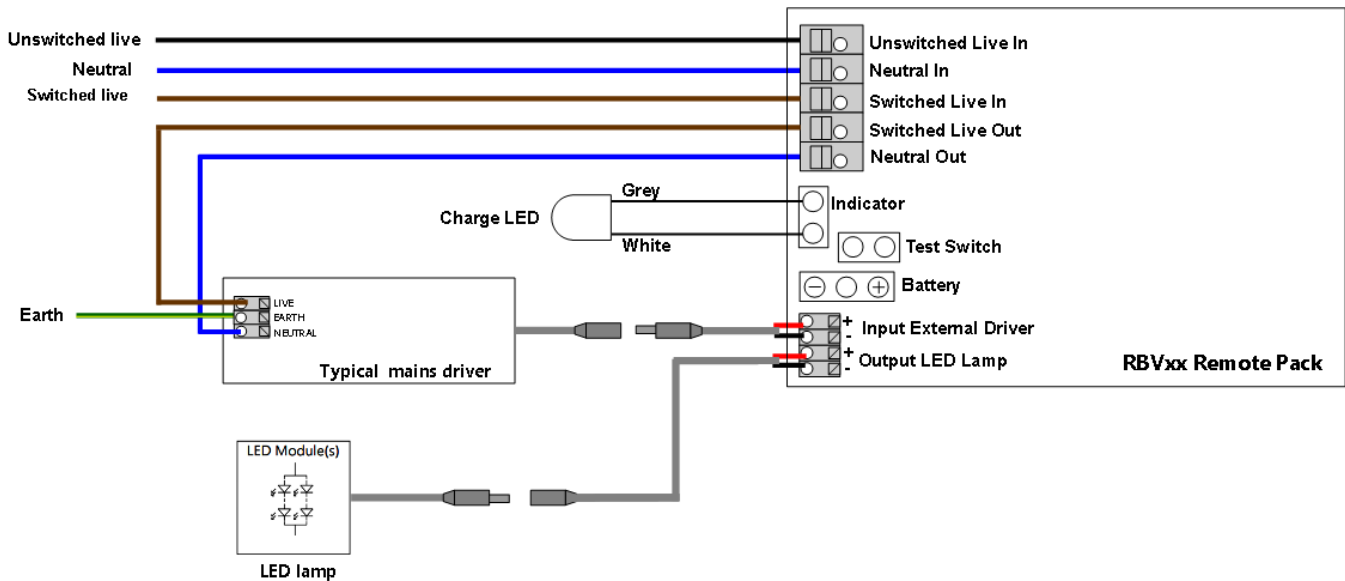

Note: Lamp and driver plug and socket may be opposite gender or different type. Observe emergency module label information for wiring!