

Product description

LED Versatile Remote™ is an effective solution for emergency conversion of luminaires using LED arrays. The compact, robust housing is supplied containing our LED emergency driver, re-chargeable LiFePO4 battery and connection terminals. A removable end cover provides easy access for wiring and its compact, low-profile design allows installation through a ceiling cut-out of just 75mm diameter. This product offers an emergency solution for a wide range of applications and can be used with a separate mains driver for Maintained applications. It is also available pre-wired with cable assemblies for simple 'plug-and-play' convenience.

British designed and manufactured emergency driver technology will run LED lamps or arrays from 10V – 80V, so making it easy to convert your existing LED luminaire without the need for separate 'emergency' LEDs or connectors.

Features

- > Ideal for use with LED panels or down-lights
- > Emergency output power options (Typical): 2W - 4W
- > Optional Self-Test functionality
- > Green charge indicator LED with 500mm leads and bezel (OB1)
- > Suitable for use with solid or stranded cables 0.2-1.5mm²
- > Molded in black UL94_V0 rated Polycarbonate
- > Options for 3 pole full isolation of lamp & mains driver power during emergency available.
- > Driver complies with: EN61347-1, EN61347-2-7, EN55015, EN61000-3-2, EN61547
- > Conforms to EN60598-1 & EN60598-2-22
- > Mating panel plug & socket connections available on request
- > Supplied with an individual protective box and packed in an outer carton of 20 pieces. (MOQ 20 pieces)

Common Technical Data	
Input Supply Voltage	230V +/- 10%
Supply Frequency	50/60 Hz
LED Voltage Range	10 - 80V DC
Battery Type	1.6Ah, 3.6Ah 6.4V LiFePO4
Ambient Temperature Range	5 - 35°C
IP Rating	IP20
Earth Leakage Current	N/A
Weight	0.3kg(2W), 0.4kg(4W)
Dimensions (mm)	245(l) x 67(w) x 32(h)
Minimum Ceiling Cut-out Size	75mm Diameter

Model Number	Battery Pack	Emergency Power
RBV80	1.6Ah LiFePO4	2W
RBV80/PLUS	3.6Ah LiFePO4	4W

For Self-Test versions add '/ST' to the model numbers above.

Please note: It is the users responsibility to ensure full compatibility of the RBV product for the intended application and for compliance of the emergency conversion to relevant Standards. Please contact our Technical department if you are in any doubt.

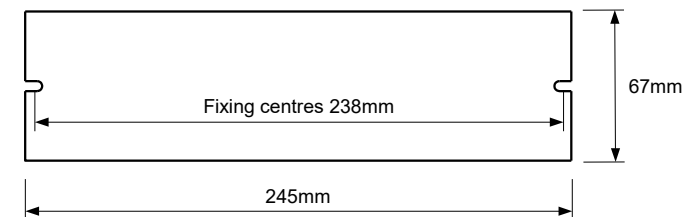
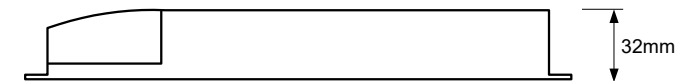

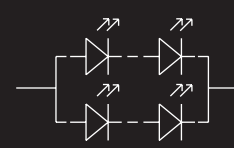

TECHNICAL INFORMATION

LED lamp output - Shaded area indicates typical forward voltage (V_f) vs forward current (I_f) expected throughout discharge duration.

RBV80

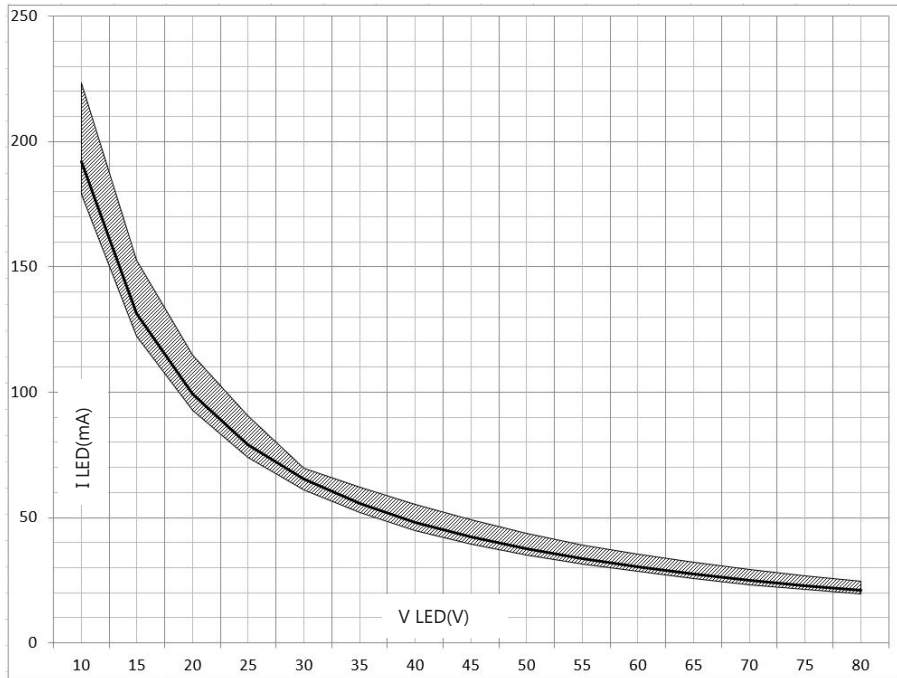

RBV80/PLUS

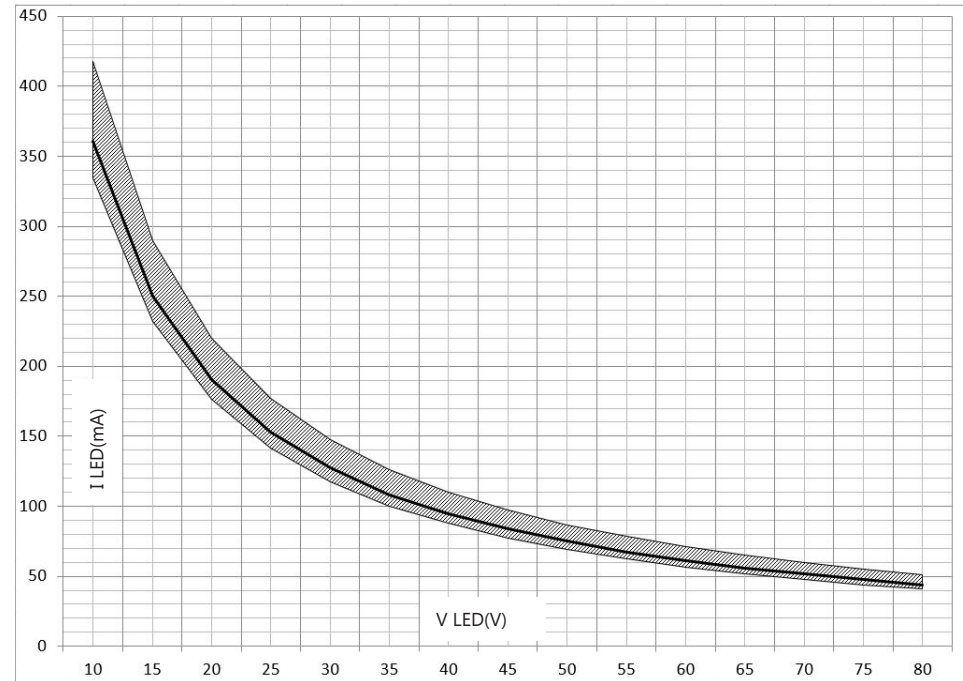

INSTALLATION

Disclaimers

This product and its associated accessory products have been manufactured and designed to comply with the requirements of EN60598-2-22 in addition to the standards detailed on page 1 of this document. Operation beyond the parameters specified in this document and the associated standards may result in reduced performance and ultimate premature failure, with the warranty made void. It is the users responsibility to ensure full compatibility of this product for the intended application and for compliance of the emergency conversion to relevant Standards. The user should be aware of the environment to which the luminaire and these components are used and follow the luminaire manufacturer's specifications. The RBV modules are not intended for use in high-risk task area luminaires. Please contact our Technical department if you are in any doubt.

Precautions

This product should be installed as per the following guidelines, electric shock or damage to the product may result if incorrectly installed. The luminaire should be installed by a qualified and competent electrician and in accordance with the current IEE wiring regulations (BS7671) and building regulations.

The emergency pack is for use with LED Modules only and can be supplied in several different wiring formats. Please refer to the appropriate diagram on page 4 of this leaflet for details of mains supply, LED driver, battery and lamp connections.

If non-locking external plug and socket connectors are used, i.e. without means to prevent accidental disconnection, the remote box should be sited so that it is protected from unauthorised disconnection.

If the luminaire is to be mounted in an external location, consider the battery as temperatures below 5°C may be frequent in cold months. In this case, the design life of 4 years will be compromised and more frequent battery replacements may be needed. Likewise, if the luminaire is situated in a hot environment where the temperature is maintained at 25°C or above, or sited next to large panes of glass in which case it may be exposed to thermal magnification. Best effort should be made to keep the unit away from direct sources of heat, i.e. mains LED drivers and LED lamps. Avoid obstructing airflow around the sides of the unit and other electronic products. Allow a clearance of 10mm or more wherever possible.

If other devices are connected to the un-switched supply, please be aware that to maintain compliance with EN60598-2-22 that in event of its failure it will not affect other devices on the same circuit. In this case we recommend the use of separate fused terminal blocks to each device. Internal fuses used within this product are not user serviceable.

Installation notes

Wire Preparation: maximum strip length 10mm (recommended 6mm)
Min/max Conductor sizes: 0.5 - 1.5 mm².

A recessed plastic bezel can be found inside the packaging carton to assist installation of the indicator LED. A 14-16mm hole should be drilled in the required location so it is visible during normal use.

Lamp Connections should be kept as short as possible and under no circumstances exceed 1m for self-contained luminaires.
The unit can be secured using both fixing points with M4 screws or similar.

Test Switch inputs - Emergency Test Function (Optional)

This product offers the facility to perform a function test for the duration which the switch is held. A non-latching push-to-make switch should be used as shown in the wiring diagram.

The unit provides reinforced insulation between the mains supply and battery charging circuit and employs self-resetting protection against short-circuit of battery terminals. Normal charging will resume automatically once a fault is removed. The mains supply should always be disconnected when servicing the luminaire.

Before use, the battery will need to be connected by plugging in the red and black lead into the appropriate socket, (See diagrams on page 3).

Once all the necessary connections have been made, affix cable clamps to secure cables in place, place the plastic end cover on and fix with screws provided to prevent unauthorised access.

When the un-switched mains supply is turned on, the green indicator LED should be illuminated as follows:

- LED on: Mains supply OK, battery connected and charging.
- LED off: Mains supply is off [or below

Commissioning

Once the luminaire has been installed and basic emergency Functionality checked, the battery should be allowed to charge for a minimum period of 24 hours before testing for its rated duration. If it is anticipated that the un-switched supply may be interrupted, it is strongly recommended that the battery is left disconnected and commissioning is delayed until the supply is stable. If the luminaire has been stored for a number of months, it may be necessary to repeat the charge/discharge process several times to re-condition the battery. After successful commissioning, the battery box label should be marked with the date of the test and the Engineer responsible.

Emergency Lighting 'standard' or 'manual' Test

The following minimum ongoing inspections and tests should be carried out:

Monthly: Momentarily switch off the mains power supply to the lighting unit. Inspect all emergency lights for satisfactory operation.

Yearly: Switch off the mains power supply to the lighting unit. Leave the unit to run for the rated period (e.g. three hours). The lights should remain operable from the battery for the whole period.

Any defects should be noted and rectified by a competent person as soon as possible. Please be aware that further inspection / testing may be required, e.g. by risk assessment / local legislation.

Batteries and Disposal

The battery has a designed service life in excess of 5 years and must be replaced when it no longer provides the rated duration (3 hours). The manufacturer of the emergency pack is committed to fulfill its obligations as a producer of batteries used in emergency lighting applications. End-of-life batteries may either be returned to the emergency pack manufacturer at the customers cost and arrangements will be made to ensure their correct disposal. Alternatively it may be more convenient for the customer to deliver end-of-life batteries to site(s) of authorized treatment facilities at their cost and it will be ensured that they are accepted back and subsequently treated to the standard required by the regulations.

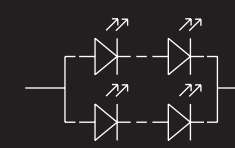

External wiring connections (Standard)

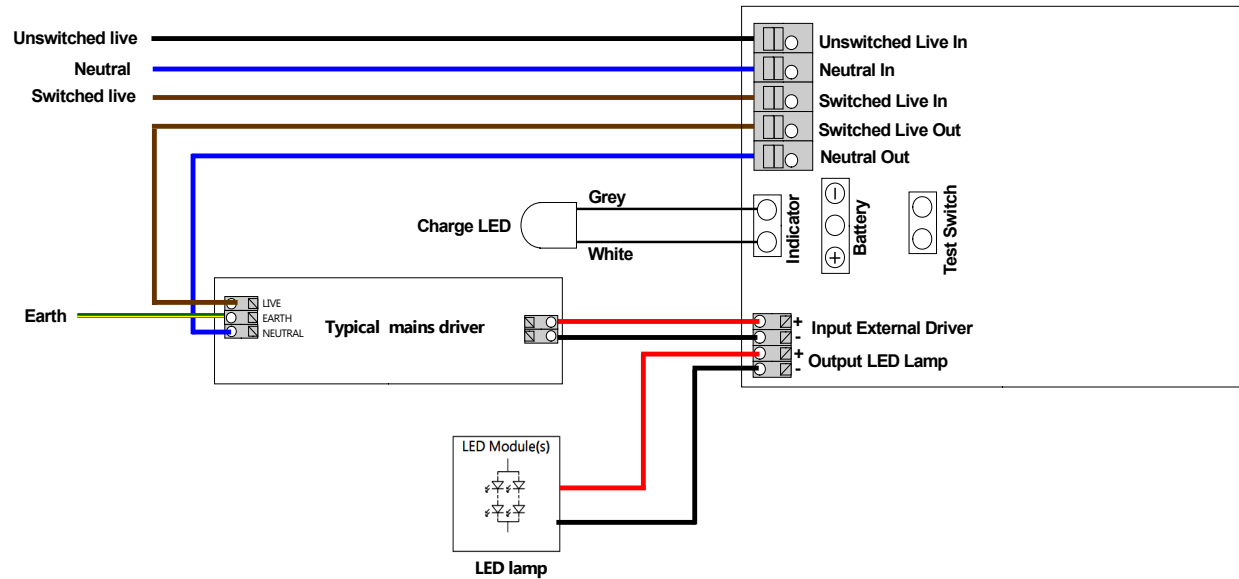

External wiring connections (With jack connectors)

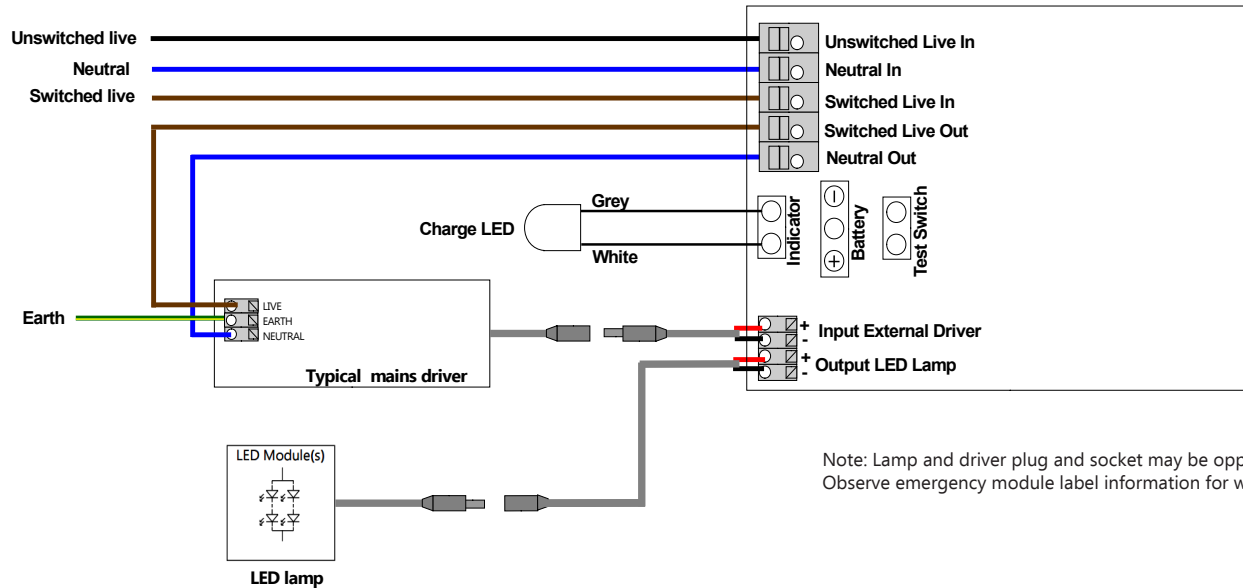

Note: Lamp and driver plug and socket may be opposite gender or different type. Observe emergency module label information for wiring!